

# PRL-425N/425T DUAL CHANNEL UNIVERSAL DIFFERENTIAL RECEIVERS, NECL/TTL OUTPUTS

## APPLICATIONS

- Differential LVDS, RS422, LVPECL, NECL, PECL or TTL to NECL, RS-422 or TTL Logic Level Translation
- Conversion of Differential Signals to Ground-Referenced Signals
- Essential Lab Tools for interfacing with High Speed Data Communications Equipment

## FEATURES

- 1.5GHz maximum Clock Rate for the PRL-425N and 300MHz for the PRL-425T
- Floating 100  $\Omega$  Universal Differential Inputs Accept LVDS, RS422, LVPECL, NECL, PECL or TTL Inputs
- Complementary 50  $\Omega$  ECL Outputs for PRL-425N
- Complementary 50  $\Omega$  TTL Outputs for PRL-425T
- Ready-to-Use 1.3 x 2.9 x 3.9-in. Modules include a  $\pm 8.5V/1.4A$  AC/DC Adapter

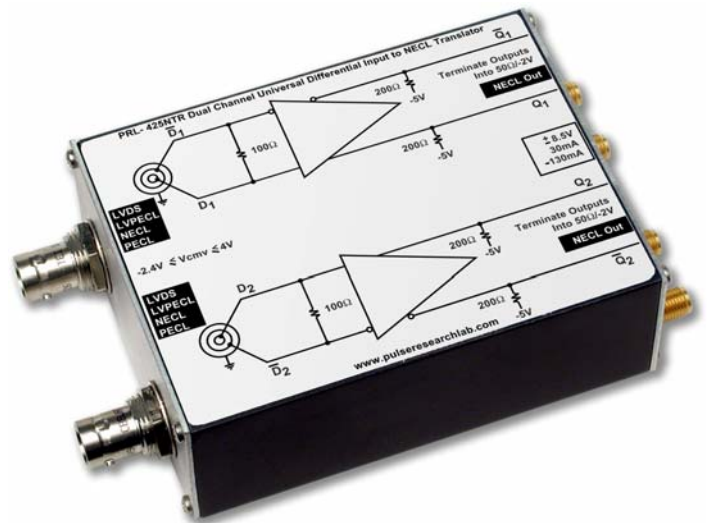

**PRL-425NTR, Universal Differential Receiver (Triax), NECL Outputs**

## DESCRIPTION

The PRL-425N and PRL-425T are dual channel, universal input differential receivers with SMA I/O connectors. The floating 100  $\Omega$  inputs are designed for interfacing with differential signals within the common mode range of -2.4V to +4V. Therefore, they are compatible with LVDS, RS422, LVPECL, LVTTTL/CMOS, NECL, PECL or TTL differential input signals. The PRL-425N has complementary NECL outputs for driving 50  $\Omega$  loads terminated to -2V, floating 100  $\Omega$  loads or AC-coupled 50  $\Omega$  loads. The PRL-425T has complementary TTL outputs for driving 50  $\Omega$  or open circuit loads. They are also long line drivers, designed specifically for use with high speed data communications applications. Functional block diagrams of these devices are shown in Fig. 1 and Fig. 2.

Model numbers with suffix TR, such as PRL-425NTR or -425TTR, have Triax input connectors instead of SMA input connectors.

Each unit is supplied with a  $\pm 8.5 V/1.4 A$  AC/DC Adaptor and housed in a 1.3 x 2.9 x 3.9-in. extruded aluminum enclosure. Available accessories include voltage distribution modules and brackets for mounting multiple units.

**\*SPECIFICATIONS (0° C ≤ T<sub>A</sub> ≤ 35°C)**

SYMBOL	PARAMETER	PRL-425N			PRL-425T			UNIT
		Min	Typ	Max	Min	Typ	Max	
R <sub>inD</sub>	Differential Input Resistance	95	100	105	95	100	105	Ω
R <sub>inC</sub>	Common Mode Input Resistance		5k			5K		Ω
I <sub>DC</sub>	DC Input Current		30/-130	40/-150		175/-365	185/-385	mA
V <sub>DC</sub>	DC Input Voltage	±7.5	±8.5	±12	±7.5	±8.5	±12	V
V <sub>AC</sub>	AC/DC Adapter Input Voltage	103	115	127	103	115	127	V
V <sub>OHNL</sub>	Output Hi Level, No Load		-0.85		4	4.6	5	V
V <sub>OHFL</sub>	Output Hi Level, Full load	-1.05	-0.95	-0.75	2	2.3	2.5	V
V <sub>OLNL</sub>	Output Lo Level, No Load		-1.65		-0.1	0	0.4	V
V <sub>OLFL</sub>	Output Lo Level, Full Load	-1.95	-1.75	-1.6	-0.05	0	0.2	V
t <sub>PLH</sub>	Propagation Delay to output ↑		1500			2200		ps
t <sub>PHL</sub>	Propagation Delay to output ↓		1500			2200		ps
t <sub>r</sub> /t <sub>f</sub>	Rise/Fall Times <sup>1</sup>		500	850		1000	1300	ps
f <sub>max I</sub>	Max Clock Frequency, SMA <sup>2</sup>	1500	1800		250	300		MHz
f <sub>max II</sub>	Max Clock Frequency, Triax <sup>3</sup>	500	625		250	300		MHz
t <sub>SKEW1</sub>	Skew between outputs		50	200		500	1200	ps
t <sub>SKEW2</sub>	Skew from unit to unit		100	400		750	1500	ps
V <sub>CM</sub>	Input Common Mode Voltage	-2.4		+4	-2.4		+4	V
	Size		1.3x2.9x3.9			1.3x2.9x3.9		in.
	Weight		5			5		Oz

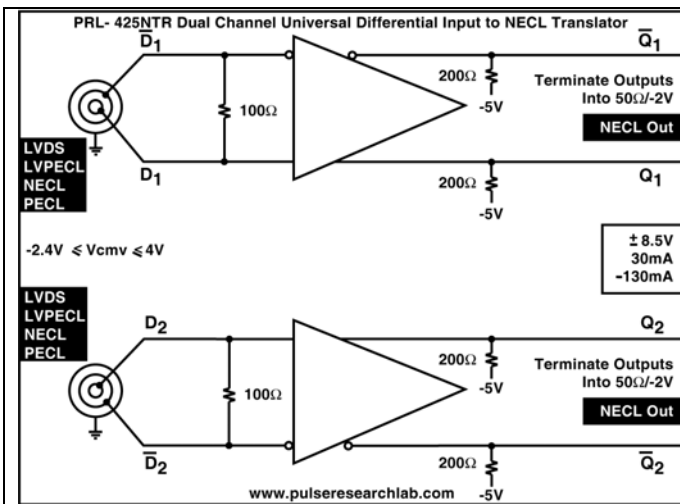

**Fig. 1 PRL-425NTR Block Diagram**

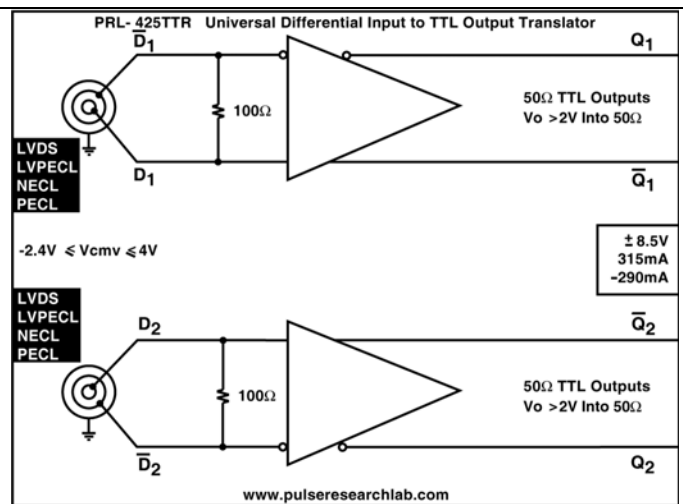

**Fig. 1 PRL-425TTR Block Diagram**

Notes: (1). The NECL 50 Ω output rise and fall times (20%-80%) are measured with both the Q and Q̄ outputs terminated into 50 Ω/-2 V. If one output is not terminated, both the rise and fall times will increase by approximately 15%, and output waveform degradation will occur. The TTL outputs rise and fall times (10%-90%) are measured with ground referenced 50 Ω terminations, and it is not necessary to terminate an unused output.  
 (2). f<sub>MAX</sub> for PRL-425N is measured by dividing the outputs by four, using the PRL-255, ÷2 and ÷4 frequency divider module, and then measured using the PRL-550NQ4X, four channel ECL Terminators, connected to a sampling 'scope. f<sub>MAX</sub> for PRL-425T is specified when V<sub>OH</sub> drops below 2.0 V into 50 Ω  
 (3). Units with the Trompeter CBBJR79 Triax input connectors are tested using the PRL-433N, complementary NECL input to Differential NECL output translator, and the Trompeter PCGOW10PCG-36 shielded twisted pair cables.



1234 Francisco Street, Torrance, CA 90502  
 Tel: 310-515-5330 Fax: 310-515-0068  
 Email: [sales@pulseresearchlab.com](mailto:sales@pulseresearchlab.com)  
[www.pulseresearchlab.com](http://www.pulseresearchlab.com)